

Hydraulic Engine Mounts

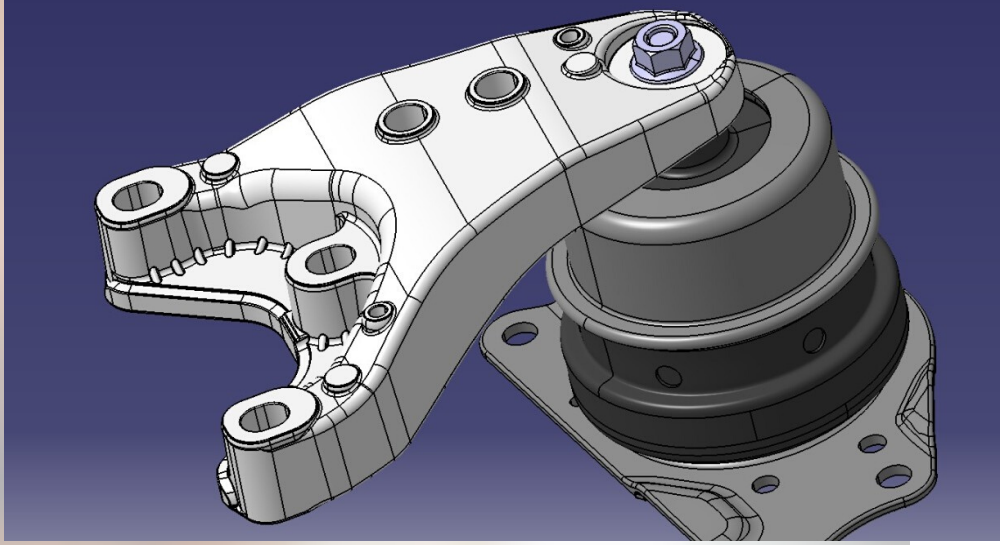

Hydraulic engine mounts on the other hand have a hydraulic fluid (water & glycol) inside of them and are characterized by a dampening capacity that is superior to that of the solid or elastomeric engine mounts.

The hydraulic engine mounts last more and offer more comfort for the driver and less vibrations that come from the engine or the road.

ÜCEL's hydraulic engine mounts and supports have proven to be highly performing in the most extreme conditions.

The quality of our spare parts is respected in 60 countries around the world thanks to our quality control.

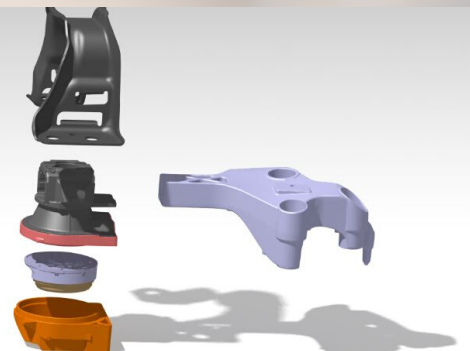

Hydraulic Engine Mounts

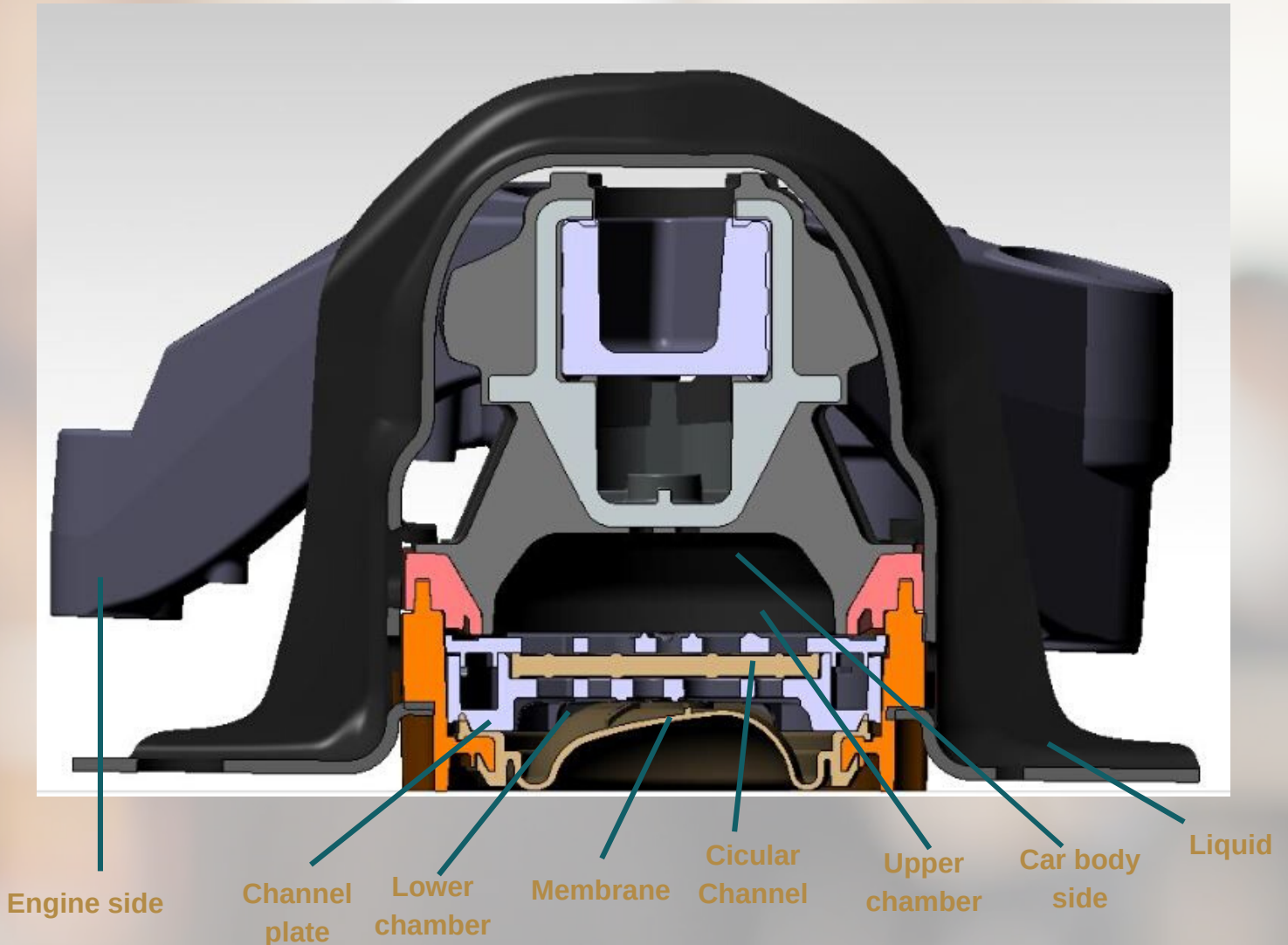

As you can see the mount is connected to the engine and with the car chassis. The pressure coming from the engine causes the engine mount to deform and make the fluid come down and up through the two chambers, and this motion of the fluid absorbs most of the vibration energy. An internal valve is designed to change the route of the fluid depending on the vibration frequency, hence yielding a more comfortable ride and longer mount life.